

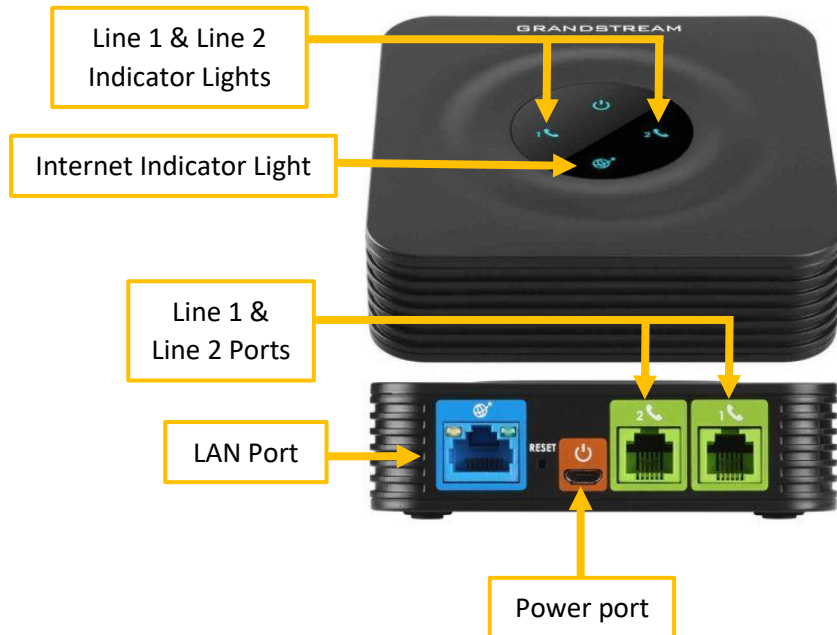

How to Plug in Grandstream ATA

Using an ATA for your TeleVoIPs Phone system converts analog devices like fax, conference equipment, or intercom systems to VoIP. When plugging in an ATA, only specific ports on the device may be active.



Steps to plug in ATA:

- 1) Plug the Ethernet cord into the LAN Port and into your internet.
- 2) Plug in the power cord.
- 3) Plug a telephone cord into the Line 1 port (green port on the right) and the desired analog device such as a fax machine.
- 4) If there is a second analog device, connect the Line 2 port.

Contact us – Once the device is properly connected, call our support team at 813.655.5100 option 2 so we can confirm the analog device is properly working with our system.